

General notes on installation

Although the materials for our hydraulic seals are particularly efficient and robust, it is nevertheless necessary to handle the seals with care to prevent mechanical damage particularly to the sealing lip which would inevitably cause leakage. In addition, prior to installation, all seals must be double checked for damage or ageing that could have occurred during transportation or storage.

To ensure safe installation of seals, please note the following:

1. For single acting seals, the seal must be installed with the prestressed side facing the direction of pressure.

2. Installation chamfers on the cylinder and on the rod are essential. The installation chamfer should be at an angle of 20°.

Recommended lengths C:

$$B = (D-d)/2$$

Profile widths B (mm)	Length of installation chamfers C (mm)
4	2
5	2.5
7.5	4
10	5
12.5	6.5
15	7.5
20	10
25	10

For the installation of wipers in axially accessible installation housings, the following installation chamfers (L) dependent on installation housing heights (H) are recommended to facilitate installation:

H (mm)	L ₁ (mm)
≤4.5	0.6
5	0.6
6	0.8
7	0.8
8	1
9	1
10	1.4
12	1.8
14	2
16	2.4

3. Edges must be deburred. Radii and chamfering must be in accordance with the installation guidelines.

4. Dust, dirt and swarf must be carefully removed.

5. Tips of screws and installation grooves for guide elements etc. should be covered using an installation cone to avoid the seal being pushed over gaps, bore holes or rough surfaces.

6. Cylinders, rods and seals must be greased or oiled before installation. However consideration must be given to compatibility with the medium.

7. Before installation seals should be heated in oil or hot water at approx. 80°C to aid expansion and facilitate fitting. With PTFE seals these can be more easily returned to their original shape and calibrated if they are first heated in oil or water to a temperature between 80°C and 120°C. When immersing seals in heated oil or water consideration should always be given to the temperature resistance of the seal material.

Using installation tools for u-rings in piston and rod applications

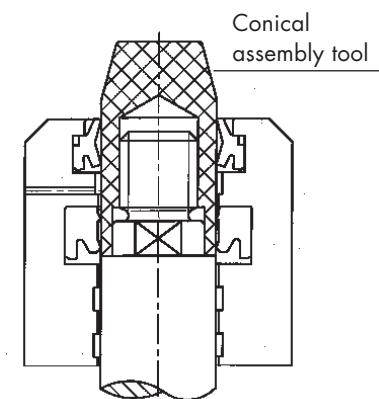
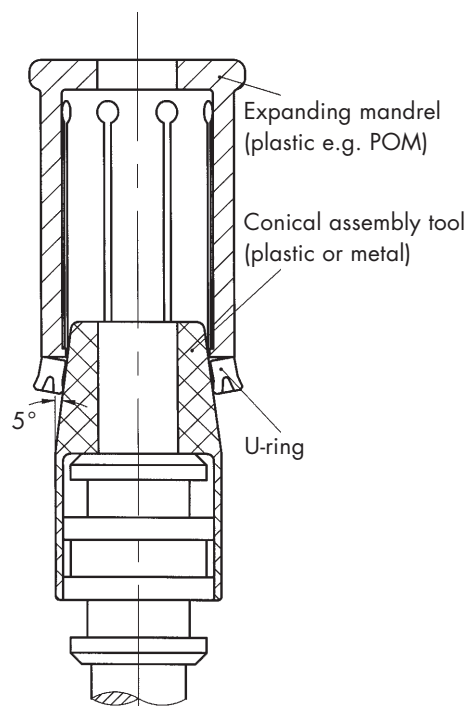

8. All installation tools such as mandrels, cones etc. should be made of soft material (e.g. POM) and must not have any sharp edges.

9. With the installation of N and NI rod seals in closed grooves, the minimum diameter d_{min} is dependent on the profile width B:

$$B = (D-d)/2$$

B(mm)	4	5	6	7.5	10	12.5	15
d_{min}	25	30	40	50	80	100	120

Standard dimensions N and NA piston seals for sizes $d > 25\text{mm}$ can generally be installed with the use of a suitable installation tool in closed or semi-open installation housings.

Fabric reinforced piston seals and Vpacking sets can only be installed in axially accessible installation housings.

Particulars for PTFE material

As PTFE has almost no elastic characteristics, PTFE seals with o-ring energising elements (SPOR 30, SPOR 31, KPOR 30, KPOR 31) must be particularly carefully installed and subsequently calibrated. With rod seals $d < 25\text{mm}$ we recommend installation in axially open installation housings. Please follow the installation guidelines below:

Installing piston seals in a closed groove

Insert O-ring flat in the groove (not twisted).

Slide the PTFE ring over a conical installation tool using an expanding mandrel until it snaps into the groove. The ring is expanded in the process.

Recalibration of the stretched PTFE ring is facilitated by the use of a calibration mandrel with an inner diameter matching the cylinder diameter.

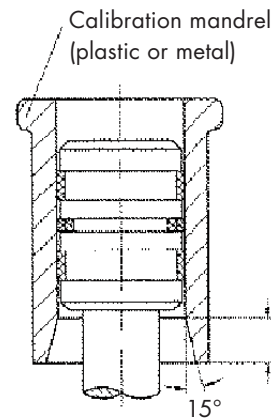
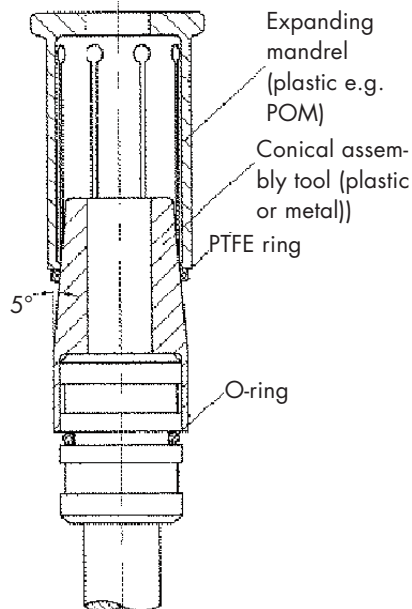

Installing rod seals in a closed groove

Insert the O-ring flat in the groove (not twisted).

Press the PTFE ring together in a kidney shape ensuring that no sharp bends are formed.

insert the compressed PTFE ring in the groove.

Calibrate using a mandrel.

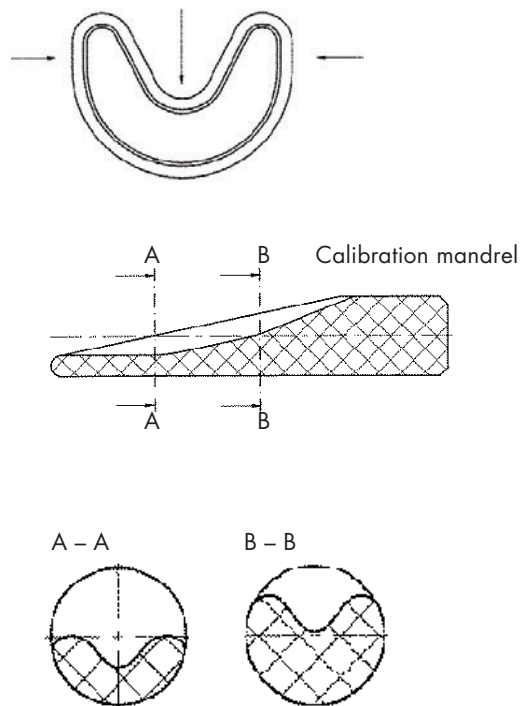

Smallest nominal seal widths that can be installed in axially closed installation housings (mm)

Seal type	Series				
	000	001	002	003	004
KPOR 30	>14	>18	>25	>45	>80
KPOR 31	>14	>18	>25	>45	>75
KK 71	>10	>12	>15	>32	>70
KNA 44	>35	>50	>70	>100	>135
SPOR 30	>10	>12	>15	>32	>70
SPOR 31	>12	>15	>20	>38	>70
SNI 43	>32	>68	>105	>290	>450